

Mini two-shaft gas turbine exergy analysis with a proposal to decrease exergy destruction

Authors

Milad Babadi Soltanzadeh ^{a*}
Mojtaba Haratian^a
MohammadSaleh Teymouri ^b

^a Department of Mechanical Engineering,
Khomeinshahr Branch, Islamic Azad University,
Isfahan, Iran

^b Young Researchers and Elite club, Islamic Azad
university Khomeini Shahr Branch, Isfahan, Iran

ABSTRACT

In this case study, exergy analysis is applied to a mini two-shaft gas turbine which is located in Islamic Azad University Khomeini Shahr Branch's Thermodynamics laboratory and a proposal presented to make exergy destruction less using a Heat Recovery Water Heater (HRWH). Calculations were done for $N_2=20000$ (rpm) constant and various N_1 and after that for $N_1=60000$ (rpm) constant and various N_2 . Results revealed that the highest exergy destruction rate occurs in combustion chamber in all conditions and a huge part of exergy destruction through the turbine exhaust. Increase in N_1 leads to increases in all component exergy destruction rates. On the other hand, power turbine is the only component which is affected by changes in N_2 and the exergy destruction rate increases with increase in N_2 . Moreover, exergy gained rate within HRWH increased with increase in N_1 and is almost constant with changes in N_2 . In the same vein, exergetic efficiency of HRWH and exergy gained rate within HRWH are increased with decrease in water outlet temperature of HRWH.

Article history:

Received : 17 August 2017

Accepted : 30 January 2018

Keywords: Gas Turbine, Exergy Analysis, Second Law Efficiency, Exergy Recovery.

1. Introduction

Gas turbines are rotary combustion engines which use air as operating fluid. These engines are used in transportation vehicles such as airplanes, helicopters, ships, trains, and gigantic military vehicles as the driving force generator. In addition, they have a big share in producing electrical power demand in the world. Power generation is the base of industrial infrastructures and economic growth. Furthermore, the most important reasons of using these engines are to reach higher power-

to-weight ratio and the ability for fast cut-in and cut-off. Most of the times, these units are used in peak load conditions. Nowadays, due to the decrease in fossil sources and the increase in environmental concerns caused by consuming these sources of energy, making these systems more efficient is a worldwide priority. Exergy analysis is a reliable way to comprehend the behavior and the optimization of these systems.

The first law of thermodynamics, which is usually used for modeling systems, is not able to determine the irreversibility sources and their amount. Moreover, the energy analysis based on the first law of thermodynamics does

* Corresponding author: Milad Babadi Soltanzadeh
Department of Mechanical Engineering, Khomeinshahr
Branch, Islamic Azad University, Isfahan, Iran
Email: milad.babadi@iaukhsh.ac.ir

not consider any differences between energy levels. Therefore, with this kind of analysis, some of the losses cannot be specified. Exergy concept is based on both the first and the second law of thermodynamics. Exergy is the most available work that can be drawn from the system through the process from initial state to the dead state which is the same state as the surroundings in a fully reversible process. In dead state, the system is in a thermo-mechanical equilibrium, which means there is no pressure and temperature gradient between the system and the environment, and also, there are no differences between potential and kinetic energy, and the system is chemically neutral. Basically, exergy doesn't have conservation and will destruct in system processes. Exergy analysis of a thermodynamic system enables us to calculate exergy losses and helps us to evaluate the real quality of energy transfer and to clarify the losses and the real irreversibility of processes and system components. At the moment, exergy analysis is a powerful tool in systems analysis, comprehension of processes; it also specifies the quality and quantity of losses in engineering applications.

Gas turbines systems are used in different ways to produce industrial and urban power demand. The first one is open cycle gas turbine which only generates electrical power. The second one is generating combined power and heat of the process (CHP). In addition, the third one is combined cycles that have both gas and steam turbines working together (Combined Cycle) and it is possible to use the extra steam as a heat supply for processes, too. Several researchers such as Shapiro and Moran [1] have worked on thermodynamic analysis of these systems. Sarabchi [2], investigated the effects of different parameters such as compressor pressure ratio and steam injection ratio on a steam injected gas turbine system operation. Yaseen [3], did an exergy analysis on a single-shaft gas turbine with steam injection and calculated the amount of exergy losses and exergetic efficiency for each component. Almasi et al. [4], did thermodynamics modeling, energy and exergo-economic analysis using genetic algorithm with the objective function of the total power plant costs. They optimized the main designed parameters such as compressor pressure ratio of the gas turbine power plant of Mahshar, Iran. Agarwal et al. [5], studied thermodynamic analysis of a simple gas

turbine. They also studied the effects of adding extra components (retrofitting) for cooling the inlet air with evaporation, steam injection and combining both methods. Mousafarash et al. [6], did exergo-economic analysis for Montazer Ghaem power plant, which included a simple gas turbine located in Iran. In addition, they studied the effects of system operation in Partial loads and different ambient temperatures on cycle operation and calculated the value of exergy destruction rate and exergetic efficiency for each component. Azimian [7], did thermo-economic analysis for two power plants cycles and optimized the components with high exergy loss. Ghazikhani [8], did exergy analysis on a simple traditional gas turbine and a combined cycle with two gas turbines at different ambient temperatures. Furthermore, he calculated thermodynamics second law efficiency for the cycle components. Sarabchi [9], in another research, addressed a parametric analysis of a cogeneration gas turbine from the first and second law of thermodynamics point of view and studied the effects of designing parameters such as process steam pressure and pinch point temperature difference on this cycle operation. In the same manner, Bilgen [10], had a study on exergy analysis of a cogeneration gas turbine cycle and calculated the first and second law efficiencies for steam extraction and calculated the power to heat ratio. In this research, first, exergy analysis of a mini two-shaft gas turbine is carried out and, in the following, a scenario is proposed in order to reduce the exergy destruction. The studied gas turbine is GT185 manufactured by TecQuipment Corporation, which is located in thermodynamic laboratory of Islamic Azad University, Khomeinishahr Branch, in the city of Isfahan, Iran. The system components are as follows:

1. Vaneless centrifugal compressor with multi-blade impeller.
2. Combustion chamber with three dilution stages.
3. Generator turbine, a vaneless centrifugal turbine that drives the compressor.
4. Power turbine (free turbine), a vaneless centrifugal turbine that drives a dynamometer.

The case that studied system schematic is shown in Fig.1.

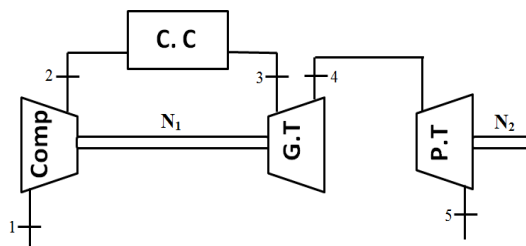

Fig. 1. Mini two-shaft gas turbine schematic

For quantitative expression and exergy modeling, both system and environment should be considered. In this case study, temperature, pressure, and ambient humidity were registered and applied individually in each data recording. This means that testing was done in one day and the environment conditions were considered as a fixed amount for each data recording, but for each series of data, these conditions were considered different and independent.

Modeling assumptions are as follows:

- Pressure and temperature before and after each component are monitored, and frictional pressure drop in pipes and fittings is negligible in exergy loss calculations.
- Changes in kinetic and potential energy of the operating fluid between the input and output components are ignored.
- Air, as the working fluid, is assumed to be the ideal gas.
- Specific heats are assumed to be varying and are calculated for each system component in average input and output temperature.
- Consumed fuel is distilled oil with low heat value of $LVH = 43760 \text{ MJ/kg}$.
- Compressor inlet temperature and pressure are not equal to ambient temperature and pressure and are monitored independently.
- Water cooling system's heat transfer is ignored.

Data recordings are carried out in two main conditions. In the first step, rotational speed of the shaft connected to power turbine (free turbine) is constant and equals to $N_2 = 20000 \text{ rpm}$ and data have been registered at variable rotational speeds of the shaft connected to compressor and generator turbine. Nevertheless, in the second step, the rotational

speed of the shaft which is connected to compressor and generator turbine is constant and equals to $N_1 = 60000 \text{ rpm}$ and data have been registered in variable rotational speeds of the shaft connected to power turbine (free turbine). From thermodynamics fundamentals perspective, the reason for low efficiency of the first and second law in gas turbine cycles is the high ratio of cycle back work (the amount of compressor's work for compressing the working fluid) to turbine's producing work and high temperature of exhausting gases. High outlet gases temperature is one of the undesirable outcomes of these cycles. Although exhausting gases not only make thermal pollution for the environment, they also carry lots of energy and exergy. Since it is very expensive and complicated to make any changes in internal system of the studied device, the most appropriate way to use this energy and exergy is to use the outlet hot exhaust gases. There are many different ways to use these gases. For example, one of these methods is using a heat recovery steam generator (HRSG) and injecting steam in combustion chamber. In this way, without affecting the function and consumption work of compressor, the output of power turbine increases. Another way is to use the steam turbine in order to convert produced steam from HRSG to useful work. On the other hand, the produced heat could be used in industrial processes. Accordingly, a proposal has been provided to recover outlet exergy from exhaust for heating purposes, and the calculation of gained exergy rate and also exergetic efficiency for heat recovery water heater (HRWH) has been carried out. Moreover, in this proposal, cycle will not make any fundamental changes in the internal structure and output exergy will also be absorbed. The temperature of inlet water stream to HRWH is considered as constant and equals to $T_a = 25^\circ\text{C}$ and calculation and exergy analysis are established for various outlet temperatures of hot water $T_b = 60, 70, 80 \text{ and } 90^\circ\text{C}$, respectively. Besides, mass flow rate of hot water is calculated in each condition.

Figure 2 shows a schematic of the system after adding the heat recovery water heater. Due to environmental considerations and reduction of NO_x and SO_x emission, temperature of hot outlet gases from HRWH is considered to be 250°C .

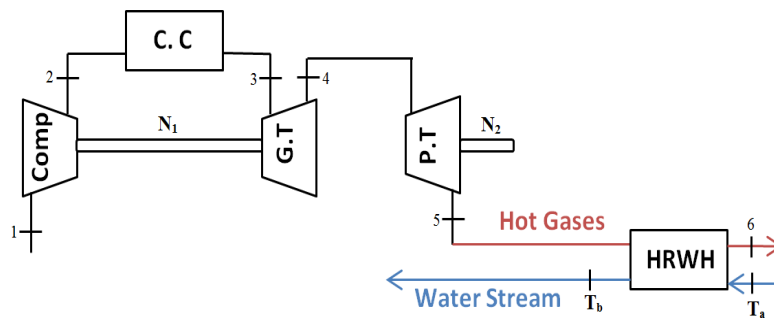

Fig. 2. System schematic after adding HRWH

Nomenclature

Symbols

c_p Specific heat capacity in constant pressure (J/kg.K)

\dot{E} Exergy rate (W)

e Specific exergy (J/kg)

g Gravity acceleration (m/s^2)

h Specific enthalpy (J/kg)

\dot{m} Mass flow rate (kg/s)

P Pressure (Pa)

\dot{Q} Heat transfer rate (W)

R Ideal gas constant (J/kg.K)

s Specific entropy (J/kg.K)

T Temperature (K)

V Volume (m^3)

v Velocity (m/s)

\dot{W} Power (W)

Z Elevation (m)

η Efficiency

ξ Constant ratio

Subscripts

air	Air
a	Heat recovery water inlet
b	Heat recovery water outlet
ch	Chemical
kn	Kinetic
ph	Physical
pt	potential
i	Inlet
e	Outlet
f	Fuel
P	Produced
S	Supplied
WH	Heat recovery water heater
0	Environment state
1	Compressor inlet
2	Combustion chamber inlet

3 Generator turbine inlet

4 Power turbine inlet

5 Heat recovery inlet

6 Heat recovery outlet

2.Exergy Analysis

Basically, exergy - athwart energy - does not conserve and will not store in a single process, but it is destructed during system processes. Exergy destruction is a measure of the irreversibility of the system which causes decrease in system's efficiency.

Exergy of substance flow can be divided into several terms. Kinetic exergy, potential exergy, physical exergy and chemical exergy. As earlier mentioned in modeling assumptions, in this research, kinetic and potential exergies are ignored. Equation (1) indicates the total amount of exergy rate of a flow.

$$\dot{E} = \dot{E}_{ph} + \dot{E}_{kn} + \dot{E}_{pt} + \dot{E}_{ch} \quad (1)$$

$$\dot{E} = \dot{m}e \quad (2)$$

Equation (2) indicates the relationship between flow exergy rate and specific exergy.

$$e = (h - h_0) - T_0(s - s_0) + \frac{v^2}{2} + gz + e_{ch} \quad (3)$$

Equation (3) shows flow specific exergy of a pure substance. By ignoring potential exergy and kinetic exergy, Eq.(3) becomes Eq.(4).

$$e = (h - h_0) - T_0(s - s_0) + e_{ch} \quad (4)$$

In the previous equation, h , s and T are enthalpy, entropy and temperature of substance flow, respectively, and the 0 indexes refer to environment state.

According to Eq.(4), the change in exergy of the flow during a process from state (1) to state (2) by assuming a constant composition

for the material of which chemical exergy is a function is described in Eq.(5).

$$\Delta e = e_2 - e_1 = (h_2 - h_1) - T_0(s_2 - s_1) \quad (5)$$

Generally, the exergy rate transport equation is defined as Eq.(6):

$$\left. \frac{dE}{dt} \right)_{c.v} = \Sigma(1 - \frac{T}{T_0})\dot{Q} - (\dot{W} - P \frac{dV}{dt}) + \Sigma \dot{m}_i e_i - \Sigma \dot{m}_e e_e - \dot{E}_{loss} \quad (6)$$

By assuming steady state - steady flow and without the presence of the work caused by moving boundary of the system, Eq.(6) will change to Eq.(7).

$$\Sigma(1 - \frac{T}{T_0})\dot{Q} - \dot{W} + \Sigma \dot{m}_i e_i - \Sigma \dot{m}_e e_e - \dot{E}_{loss} = 0 \quad (7)$$

Chemical exergy is the function of composition of matter. Equation (8) indicates an experimental equation for hydrocarbon fuels [11].

$$\xi = \frac{e_{ch_f}}{LHV_f} \quad (8)$$

LHV is Low Heat Value and is a constant coefficient. The f index refers to properties of the fuel. For hydrocarbon fuels, the amount of the constant coefficient of ξ is pretty close to the unit value. In this research, $\xi = 1$ is considered.

Exergetic efficiency (second law efficiency) in steady flow situation is expressed by Eq.(9):

$$\eta_{ex} = \frac{\dot{E}_P}{\dot{E}_S} \quad (9)$$

The exergetic efficiency is useful when we want to study the similar systems.

Table (1) shows the analysis calculations for each component. Used indexes are associated with the flow status in Fig.1. Ideal gas enthalpy change and entropy change equations have been used in all statements. In this case, Eq.(10) will be derived from Eq.(5):

$$\Delta e = e_2 - e_1 = c_p(T_1 - T_2) - T_0 \left[c_p \ln\left(\frac{T_2}{T_1}\right) - R \ln\left(\frac{P_2}{P_1}\right) \right] \quad (10)$$

Assuming that HRWH is selected as a cross flow shell-tube heat exchanger, Eq.(11) and (12) can be used for exergy analysis for such a component [12].

$$\dot{E}_{gained-WH} = (\dot{m}_w c_{p_w}) T_0 \left[\left(\frac{T_b - T_a}{T_0} \right) - \ln\left(\frac{T_b}{T_a}\right) + \left(\frac{\Delta P_w}{\rho_w c_{p_w} T_0} \right) \right] \quad (11)$$

$$\eta_{ex-WH} = \frac{\dot{E}_{gained-WH}}{(\dot{m}_a + \dot{m}_f)[e_5 - e_6]} \quad (12)$$

Table 1. Exergy destruction rate and Exergetic Efficiency of each component modeling

Component	Exergy Loss	Exergetic Efficiency
Compressor	$\dot{E}_{loss} = -\dot{W}_c + \dot{m}_a (e_1 - e_2)$	$\frac{\dot{E}_2 - \dot{E}_1}{\dot{W}_C} \times 100$
Combustion Chamber	$\dot{E}_{loss} = \dot{m}_f LHV_f + \dot{m}_a (e_2 - e_3)$	$\frac{\dot{E}_3}{\dot{m}_a e_2 + \dot{m}_f LHV_f} \times 100$
Generator Turbine	$\dot{E}_{loss} = -\dot{W}_{GT} + (\dot{m}_f + \dot{m}_a)(e_3 - e_4)$	$\frac{\dot{W}_{GT}}{\dot{E}_3 - \dot{E}_4} \times 100$
Free Turbine	$\dot{E}_{loss} = -\dot{W}_{FT} + (\dot{m}_f + \dot{m}_a)(e_4 - e_5)$	$\frac{\dot{W}_{FT}}{\dot{E}_4 - \dot{E}_5} \times 100$

3. Results and Discussion

Exergy analysis has been done for each component in two situations; first, at constant rotational speed of $N_2=20000$ rpm and various rotational speed of N_1 . Likewise, at constant speed of $N_1=60000$ rpm and various speed of N_2 . All model governing equations are solved coupled using a computer code and results are provided graphically. Figure 3 shows exergy destruction rate in compressor, combustion chamber, generator turbine and power turbine in $N_2=20000$ rpm and variable N_1 , respectively. According to Fig.3, exergy destruction rate increases in compressor by increasing the rotational speed of compressor. Moreover, increase in compressor's speed leads to higher pressure ratio in compressor. Therefore, it can be concluded that an increase in pressure ratio in compressor, leads to more exergy destruction rate. Referring to calculations, specific exergy destruction rate (exergy per unit of inlet mass flow rate to compressor) also increases greatly with the increase in rotational speed and pressure ratio. It seems that because of the divergence of iso-baric lines in T-S diagram, because of the increase in pressure, entropy production and irreversibility of the process increases. Since speed and pressure ratio are not constant, we cannot comment on the effect of inlet temperature on compressor's exergy destruction, but previous research studies indicate that the increase in inlet temperature will lead to more exergy destruction rate, too. Although with increase in rotational speed of the first shaft, exergy destruction rate in combustion chamber increases. Increase in compressor's speed, increases combustion chamber input temperature. This implies that more exergy enters into combustion chamber, but because of the increase in input mass flow rate to combustion chamber, exergy destruction rate increases. Exergy destruction rate in combustion chamber is very high and that is because of fuel and air mixing, production and destruction of new chemical compounds in combustion products and also because of high temperature gradient between flame and input air stream. Likely, exergy destruction in generator turbine increases with increase in the first shaft's rotational speed, too. The main reasons are the increase in inlet mass flow rate to generator turbine and the increase in pressure ratio due to the increase in N_1 rotational speed. Likewise, specific exergy destruction increases with increase in rotational speed. Besides, exergy destruction rate increases with increase in N_1 rotational speed in free turbine.

Changes of exergy destruction rate in lower speeds are less than changes of exergy destruction rate at higher speeds. According to previous reasons, it can be concluded that an increase in pressure ratio in compressor has led to growth in exergy destruction rate in free turbine. According to Fig.3, in all components, an increase in rotational speed of N_1 , which also leads to an increase in pressure ratio in compressor, causes an increase in inlet flow in cycle and an increase in the rate of exergy destruction. It is obvious that the maximum exergy destruction rate occurs in combustion chamber with a great difference from other components. Thereafter, the biggest exergy destruction rate occurs in power turbine, generator turbine and the compressor, respectively. Exergetic efficiency of each component at different speed of N_1 is indicated in Fig.4 in a comparative method. Figure 4 shows that with an increase in compressor's speed N_1 and an increase in pressure ratio in compressor, exergetic efficiency of the compressor decreases. The reason for this phenomenon seems to be a decrease in compressor's inlet exergy due to created partial vacuum in inlet duct and filters. Moreover, with an increase in partial vacuum, compressor's inlet pressure and temperature decreases. Thereupon, exergy of inlet mass flow decreases greatly. On the other hand, exergy destruction rate increases simultaneously and compressor's exergetic efficiency decreases. On the contrary, by the increase in N_1 , the exergetic efficiency of generator turbine, combustion chamber and power turbine increases. The greatest increase in exergetic efficiency can be seen in the free turbine. It seems that the increase in exergetic efficiency in combustion chamber and other components is the result of an increase in inlet exergy to these components. It has occurred because an increase in speed leads to an increase in compressor's outlet temperature and pressure. Therefore, as the compressor's outlet exergy increases, inlet exergy of the downstream cycle components increases. Figure 5 shows exergy destructions in compressor, combustion chamber, generator turbine and power turbine at constant speed of $N_1=60000$ rpm and various speed of N_2 , respectively. According to the results, exergy destruction rate in compressor, combustion chamber and generator turbine is almost constant and there is no dependency on changes in speed of N_2 and it is only a function of changes in N_1 . This is due to constant inlet mass flow to these components and also constant pressure ratio of compressor. On the other hand,

with an increase in speed of N_2 which leads to an increase in pressure ratio in free turbine, exergy destruction rate in power (free) turbine increases greatly. In fact, power turbine is the only component whose exergy destruction rate is a function of N_2 . Moreover, exergetic efficiency of free turbine's upstream components is almost constant to changes in N_2 , because inlet and outlet exergy and also exergy destruction rate are constant. However, Fig. 6 indicates that, by increasing N_2 , power turbine's exergetic efficiency decreases greatly. This is due to the increase in exergy destruction rate in turbine. Adding a heat recovery water heater (HRWH) indicates interesting results in exergy recovery of outlet hot gases. Figures 7 and 8 represent outlet exergy of free turbine exhaust, gained exergy through heat recovery and exergetic efficiency of HRWH in a comparative method, at first for constant speed of $N_2=20000$ rpm and variable speed of N_1 and after that for constant speed of $N_1=60000$ rpm and variable speed of N_2 , when the temperature of inlet water to HRWH is $T_a=20^\circ\text{C}$ and the temperature of outlet water of HRWH is $T_b=80^\circ\text{C}$, respectively. According to Fig.7, by increasing the speed of N_1 , outlet exergy rate of exhaust increases. Therefore, gained exergy rate in HRWH increases, too. Furthermore, this leads to a relative stability in exergetic efficiency of HRWH. Of course, by increasing the speed of N_1 , a slight increase in exergetic efficiency occurs. Figure 8 shows that with the constancy of the N_1 speed and change in the speed of N_2 , outlet exergy rate from exhaust, exergy rate gained from flow, and exergetic efficiency of HRWH are almost constant. This means that mentioned parameters are not the functions of N_2 . Outlet temperature of HRWH

has an impressive effect on mass flow rate of the heated water and exergetic efficiency; these facts are respectively shown in Fig.9. According to Fig.9, by decreasing the temperature of outlet heated water from HRWH, heated water flow rate in all speeds of N_1 will increase. Moreover, at a constant temperature of outlet heated water, by increasing the speed of N_1 , flow rate of heated water will increase. Figures 10 and 11 respectively indicate exergetic efficiency of HRWH, at constant speed of $N_2=20000$ rpm and various speed of N_1 , and at constant $N_1=60000$ rpm and various speed of N_2 for different temperatures of outlet heated water. According to Fig.10, at a constant outlet temperature, an increase in N_1 leads to a slight increase in exergetic efficiency. Furthermore, at a constant speed of N_1 , a decrease in temperature of outlet heated water leads to an increase in exergetic efficiency of HRWH. The reason for this can be described by Fig.9. By decreasing the temperature of outlet heated water, flow rate of the heated water increases greatly. Increasing the amount of heated water flow leads to an increase in gained exergy rate of HRWH. Therefore, in a unique situation, with constant inlet exergy to HRWH, the amount of gained exergy rate increases and exergetic efficiency will increase. According to Fig.11, at a constant outlet temperature, exergetic efficiency of HRWH is not a function of N_2 speed. This is due to the constancy of gained exergy rate and also in outlet exergy rate from exhaust for various speeds of N_2 , which is obvious in Fig.8. However, decreasing the temperature of outlet heated water at a constant speed of N_2 , similarly, will lead to an increase in the exergetic efficiency in HRWH.

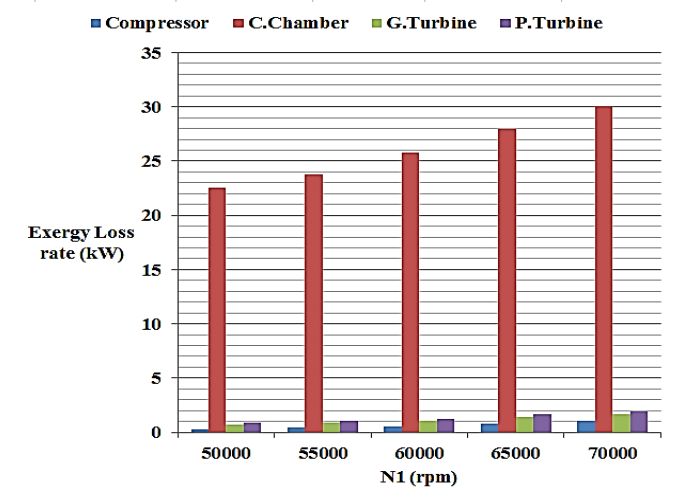

Fig. 3. Component exergy loss rate $N_2=20000$ (rpm)

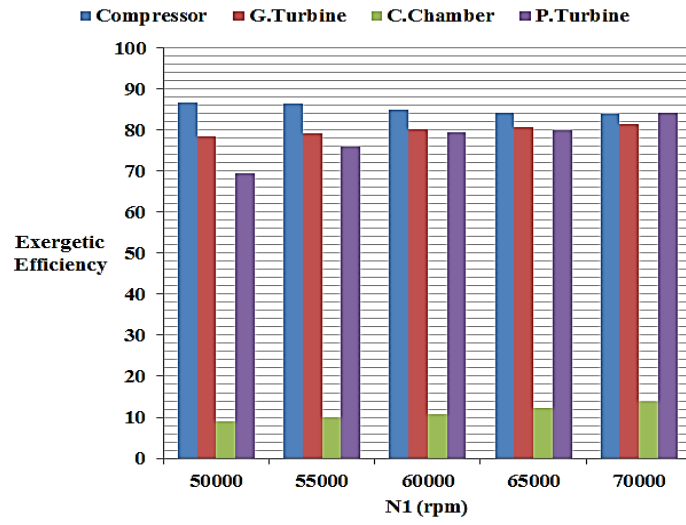

Fig. 4. Component exergetic efficiency $N_2=20000$ (rpm)

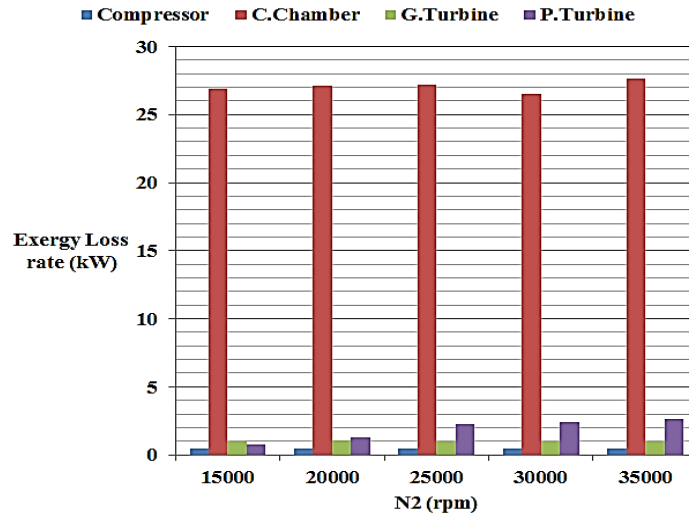

Fig. 5. Component exergy loss rate $N_1=60000$ (rpm)

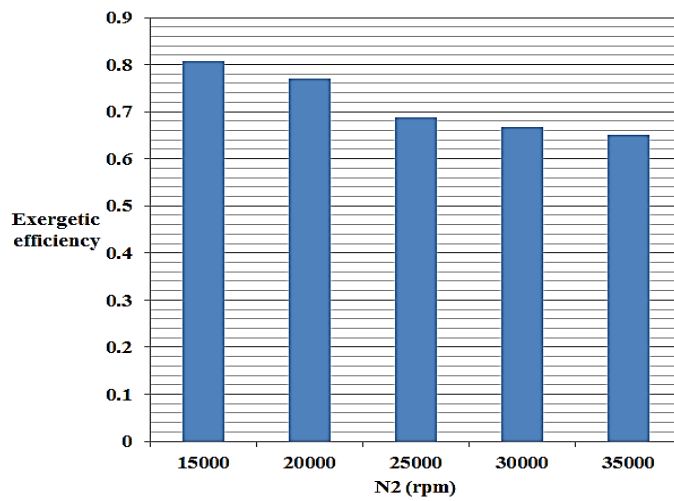

Fig. 6. Power Turbine exergetic efficiency $N_1=60000$ (rpm)

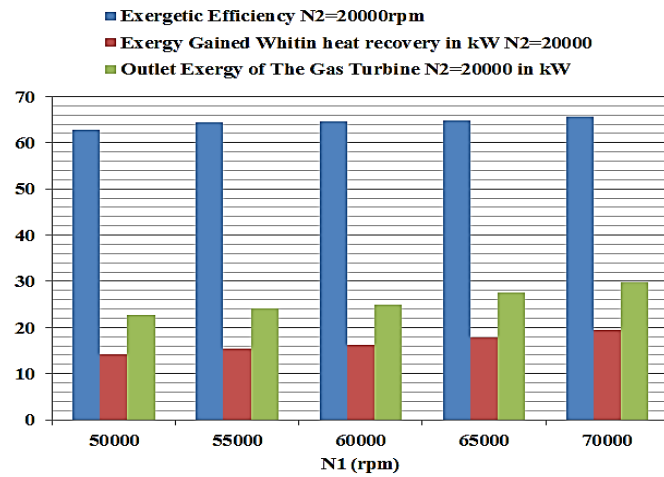

Fig. 7. HRWH Exergetic efficiency, Exergy gained within HRWH and outlet exergy of the gas turbine $N_2=20000$ (rpm)

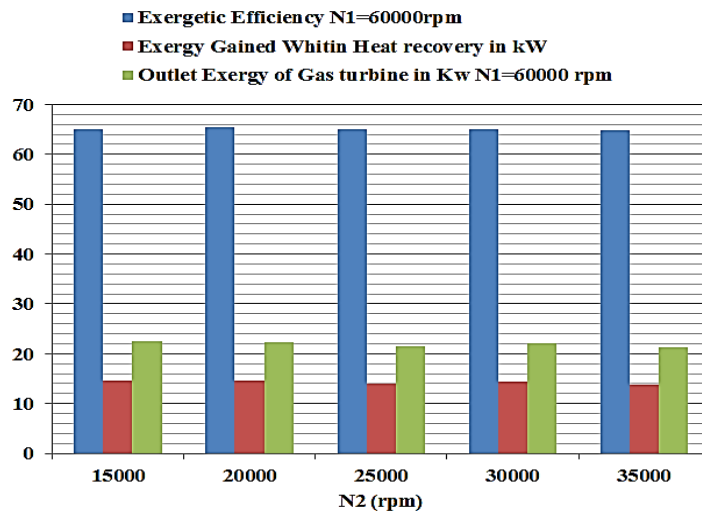

Fig. 8. HRWH Exergetic efficiency, Exergy gained within HRWH and outlet exergy of the gas turbine $N_1=60000$ (rpm)

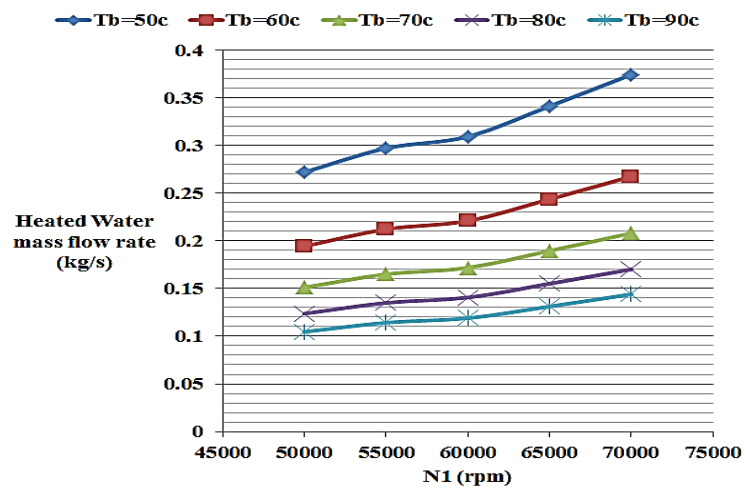

Fig. 9. Mass flow rate of heated water in various outlet temperature $N_2=20000$ (rpm)

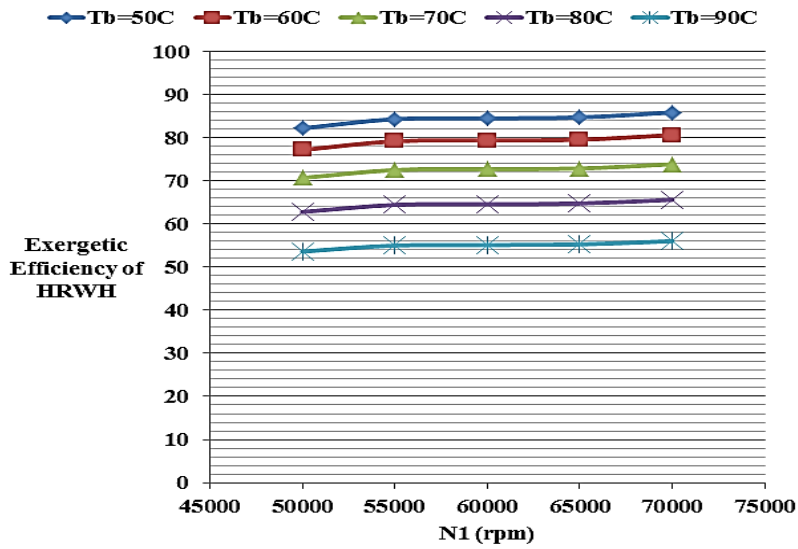

Fig. 10. Exergetic efficiency of HRWH in various outlet temperature $N_2=20000$ (rpm)

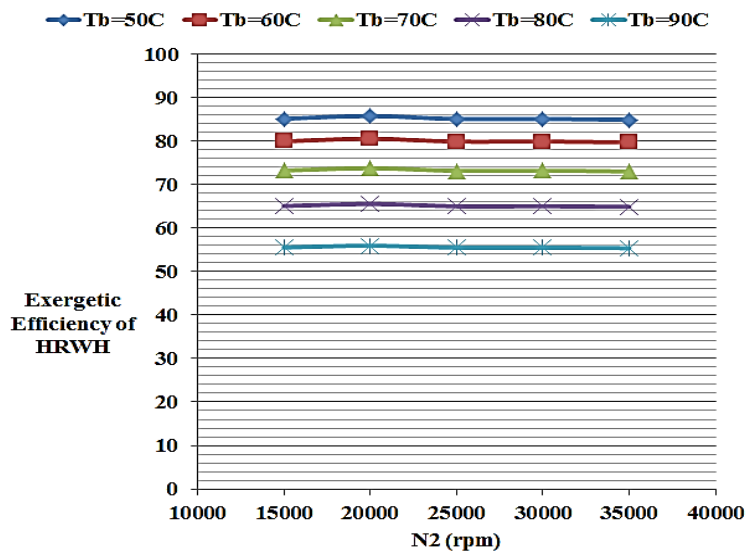

Fig. 11. Exergetic efficiency of HRWH in various outlet temperature $N_1=60000$ (rpm)

4. Conclusions

In this study, exergy analysis for a mini two-shaft gas turbine has been performed. The governing equations of each component are solved. Coupled and exergy destruction rate and exergetic efficiency for each component has been calculated. Results have been presented graphically for constant speed of $N_2=20000$ rpm and variable speed of N_1 and also for constant speed of $N_1=60000$ rpm and variable speed of N_2 . According to the results, combustion chamber has shown maximum rate of exergy destruction and also minimum exergetic efficiency among all of the components. Increasing the speed of N_1 leads

to an increase in exergy destruction rate in all components. Although the compressor's exergetic efficiency is decreased with increase in N_1 , it increased in other components. Exergy destruction rate and exergetic efficiency are independent of N_2 speed for every component except the free turbine, where exergy destruction rate has been increased and exergetic efficiency has been decreased by increasing the speed of N_2 . For exergy recovery of outlet hot gases flow from exhaust, a heat recovery water heater has been proposed. Using HRWH causes regenerating of the outlet exergy rate by 55-85% for inlet water temperature of $T_i=25^\circ\text{C}$ and outlet

temperatures of $T_b=50, 60, 70, 80, 90^\circ\text{C}$. Increasing the speed of $N1$ leads to an increase in outlet exergy from exhaust, an increase in gained exergy in HRWH, and an increase in exergetic efficiency of HRWH. Moreover, a decrease in outlet temperature T_b from HRWH leads to an increase in hot water flow and an increase in exergetic efficiency of HRWH. The proposed scenario can recover a big share of exergy loss from gas turbine's exhaust for heating purposes.

References

- [1] Moran M., Shapiro H., Fundamentals of Engineering Thermodynamics, 4th Edition, Wiley, New York (2000).
- [2] Sarabchi K., Parametric Analysis of Steam Injected Gas Turbine Cycle, IGTI ASME COGEN-TURBO ASME(1992) 7: 209-214.
- [3] Yaseen A. A. R., Exergy Analysis of a Single-Shaft Gas Turbine Power Plant with Steam Injection, Wasit Journal for Science and Medicine (2008) 2(1):116-132.
- [4] Almasi A., Barzegra Avval H., Ahmadi P., Najafi A. F., Thermodynamic Modelling, Energy and Exergoeconomic Analysis and Optimization of Mahshar Gas Turbine Power Plant, Proceedings of the Global Conference Onglobal Warmin, Lisbon, Portugal (2011).
- [5] Agarwal S., Mishra R. S., Thermodynamic Analysis for Improvement in Thermal Performance of a Simple Gas Turbine Cycle Through Retrofitting Techniques (Inlet Air Evaporating Cooling, Steam Injection & Combined IAC and STIG), Proceeding of National Conference on Trend and Advances in Mechanical Engineering, YMCA University of Science and Technology, India (2012).
- [6] Mousafarash A., Ameri M., Exergy and Exergo-Economic Based Analysis of a Gas Turbine Power Generation System, Journal of Power Technologies (2013) 93 (1):44-51.
- [7] Azimian A. R., Thermo-Economic Analysis of Power Cycles, Esteghlal (2005) 24 (1): 413-424.
- [8] Ghazikhani M., Takdehghan H., Mousavi Shayegh A, Exergy Analysis of Gas Turbine Air-Bottoming Combined Cycle for Different Environment Air Temperature, Proceedings of 3rd International Energy, Exergy and Environment Symposium (2007).
- [9] Sarabchi K., Parametric Analysis of Gas Turbine Cogeneration Plant from First and Second Law Viewpoint, IGTI, ASME COGEN-TURBO ASME (1992) 7:485-490.
- [10] Bilgen E., Exergetic and Engineering Analyses of Gas Turbine Based Cogeneration Systems, Energy (2000) 25: 1215-1229.